

IDS-100808B-CSRR

10.3125Gbps LC Receptacle Duplex SFP+ Transceiver

- **850nm Multi-Mode SFP+ Transceivers**
- **Compliant with MSA SFP+ specification**
- **Single +3.3V Power Supply**
- **Duplex LC Connector**
- **Distance up to 300m @50 / 125 um MMF**

Features

- Standard Small Form Pluggable package with receptacle LC/UPC connector
- Compliant with SFP MSA
- SFF-8472 compliant digital diagnostic monitoring function implemented
- Internally calibrated mode
- 850nm VCSEL Transmitter
- High sensitive PIN photodiode Receiver
- Single +3.3V power supply
- Operating case temperature : 0 °C to 70 °C
- Differential CML inputs and outputs
- Internally AC-Coupled electrical interface
- RoHS compliant

Description

IDS-100808B-CSRR SFP+ transceivers are designed to meet serial optical data communications specification. The transceivers are manufactured in hot pluggable capability package with receptacle LC connector interface and made of metallized housing to obtain excellent EMI shielding.

The transmitter consists of VCSEL laser in an optical subassembly (OSA).

The OSA is driven by a custom IC which converts differential CML logic signals into a laser diode drive current. The receiver includes a planar InGaAs PIN-PD mounted with a transimpedance preamplifier IC in an OSA. The OSA is mated to a custom limiting-amplifier which provides post-amplification and signal detect function (Logic 0 indicates normal operation).

The transceivers are designed to used in a single power supply (+3.3V) and an operating temperature range of 0°C to 70°C

Applications

- Digital Wireless Repeaters
- 10GBASE-SW at 9.953Gbps
- 10GBASE-SR at 10.3125Gbps
- Other Optical links

IDS-100808B-CSRR

Absolute Maximum Ratings

Parameter	Symbol	Min	Typ	Max	Unit
Storage Temperature	T_{ST}	-40		+85	°C
Power Supply Voltage	V_{CC}	0		3.6	V
Operating Humidity	H_{OP}			85	% RH

Recommended Operating Conditions

Parameter	Symbol	Min	Typ	Max	Unit
Operating Case Temperature	T_C	0		70	°C
Supply Voltage	V_{CC}	3.15	3.3	3.45	V
Power Supply Current	$I_{CC(Tx+Rx)}$			300	mA

Transmitter Characteristics

Parameter	Symbol	Min	Typ	Max	Unit
Bit rate	B		10.3125		Gbps
Wavelength	λ_c	840	850	860	nm
Output Spectral Width (RMS)	$\Delta\lambda$			0.85	nm
Average Launch Power	P_o	-7.3		-1	dBm
Extinction ratio	dB	3			dB
Differential data input swing	$V_{IN, p-p}$	180		700	mV
TX_Disable Input High Voltage	V_{IH}	2.0		$V_{CC}+0.3$	V
TX_Disable Input Low Voltage	V_{IL}	0		0.8	V
TX_Fault Output High Voltage	V_{OH}	$V_{CC} - 0.5$		V_{CC}	V
TX_Fault Output Low Voltage	V_{OL}	0		0.4	V

IDS-100808B-CSRR

Receiver Characteristics

Parameter	Symbol	Min	Typ	Max	Unit
Bit rate	B		10.3125		Gbps
Wavelength	λ_R	840		860	nm
Differential data output swing	$V_{OUT, p-p}$	300		850	mV
RX_LOS Output Voltage-high	V_{OH}	2		V _{CC}	V
RX_LOS Output Voltage-Low	V_{OL}	0		0.8	V
Average Rx Sensitivity (Note1)	P_{min}			-9.9	dBm
Maximum Input Power	P_{max}	-1			dBm
LOS De-Assert	LOS _D			-15	dBm
LOS Assert	LOS _A	-32			dBm
LOS Hysteresis	LOS _{HYS}	0.5			dB

Note 1) Minimum sensitivity and saturation level at 10.3125 Gb/s, BER 1×10^{-12} for a $2^{31}-1$ PRBS.

IDS-100808B-CSRR

PIN description

These devices can be installed in or removed from any MSA-compliant Pluggable Small Form Factor port regardless of whether the host equipment is operating or not. These devices are simply inserted, electrical-interface first, under finger-pressure. Controlled hot-plugging is ensured by 3-stage pin sequencing at the electrical interface. See the Fig. 1. As these devices are inserted, first contact is made by the housing ground shield, discharging any potentially component-damaging static electricity. Ground pins engage next and are followed by TX and RX power supplies. Finally, signal pins are connected.

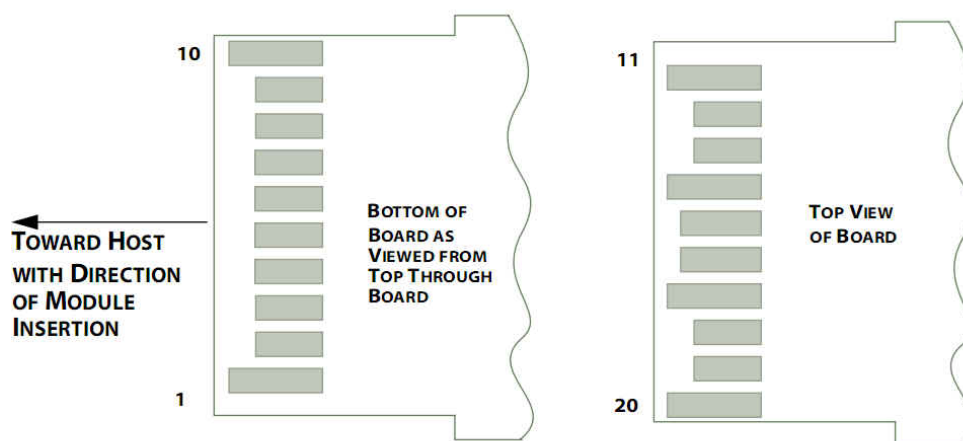

Fig. 1 SFP+ Transceiver Electrical Pad Layout

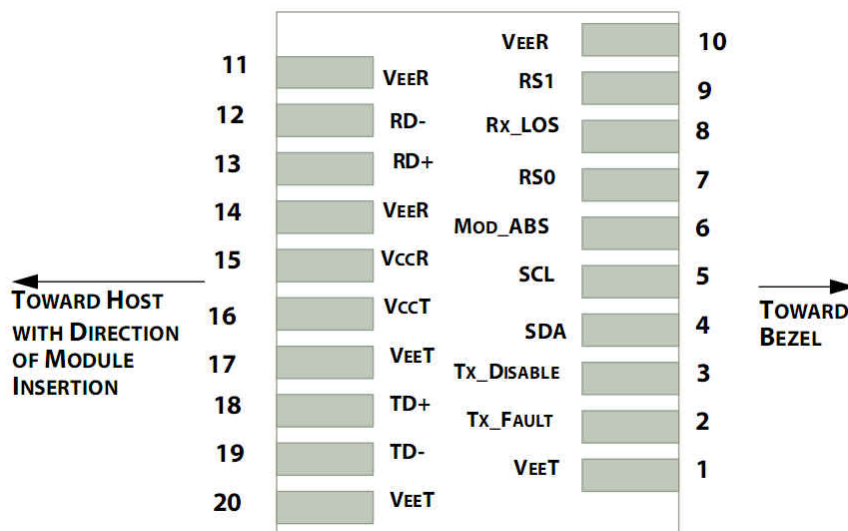

Fig. 2 Host PCB SFP+ Pinout

IDS-100808B-CSRR

PIN assignment

Pin	Name	In/Out	Logic	Description	Note
1	VeeT			Module Transmitter Ground	
2	TX_Fault		LVTTTL	Module Transmitter Fault	2
3	TX_Dis	I	LVTTTL	Transmitter Disable; Turns off transmitter laser output	3
4	SDA	I/O	LVTTTL	2-Wire Serial Interface Data Line	
5	SCL	I/O	LVTTTL	2-Wire Serial Interface Clock	
6	Mod_ABS			Module Absent, connected to VeeT or VeeR in the module	2
7	RS0	I	LVTTTL	Rate Select 0 (not functional for 10GE type)	
8	RX_LOS	O	LVTTTL	Receiver Loss Of Signal Indication (In FC designated as RX_LOS and in Ethernet designated as Signal Detect)	2
9	RS1			No connection required	
10	VeeR			Module Receiver Ground	1
11	VeeR			Module Receiver Ground	1
12	RD-	O	CML	Receiver Inverted Data Output	
13	RD+	O	CML	Receiver Non-Inverted Data Output	
14	VeeR			Module Receiver Ground	1
15	VccR			Module Receiver 3.3 V Supply	
16	VccT			Module Transmitter 3.3 V Supply	
17	VeeT			Module Transmitter Ground	1
18	TD+	I	CML	Transmitter Non-Inverted Data Input	
19	TD-	I	CML	Transmitter Inverted Data Input	
20	VeeT			Module Transmitter Ground	1

Note

- 1: Module ground pins are isolated from the module case and chassis ground within the module.
- 2: Shall be pulled up with 4.7k to 10k ohm to a voltage between 3.15V and 3.45V on the host board.
- 3: Shall be pulled up with 4.7k to 10k ohm to VccT in the module.

IDS-100808B-CSRR

SFP+ Host Board Mechanical Layout [unit: mm]

A typical host board mechanical layout for attaching the SFP+ connector and cage system is shown in Fig. 3 and Fig. 4.

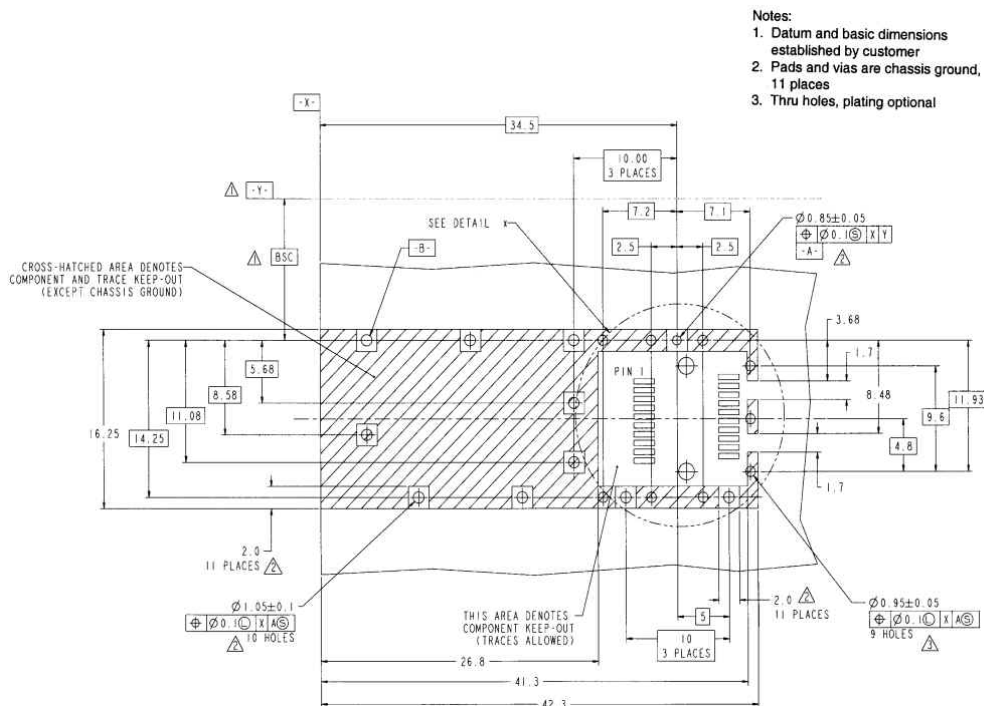

Fig. 3 Host board mechanical layout(mm)

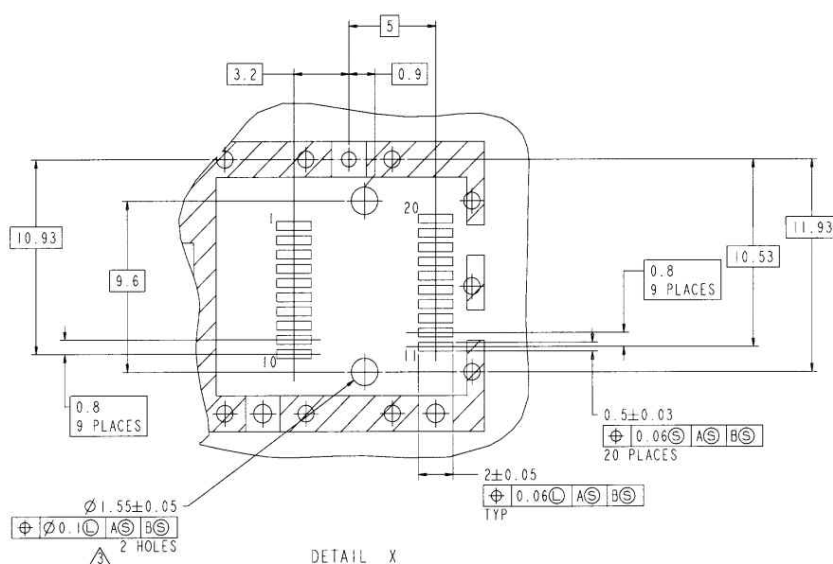

Fig. 4 Detailed host board mechanical layout(mm)

IDS-100808B-CSRR

Host Board Power Supply filtering

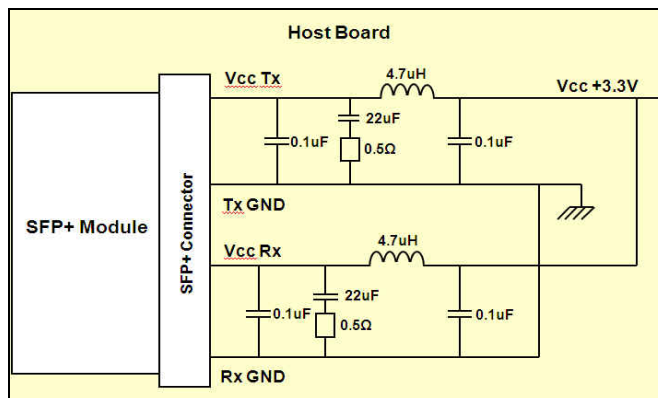

Fig. 5 Host board power supply filtering

Recommended Circuit Schematic

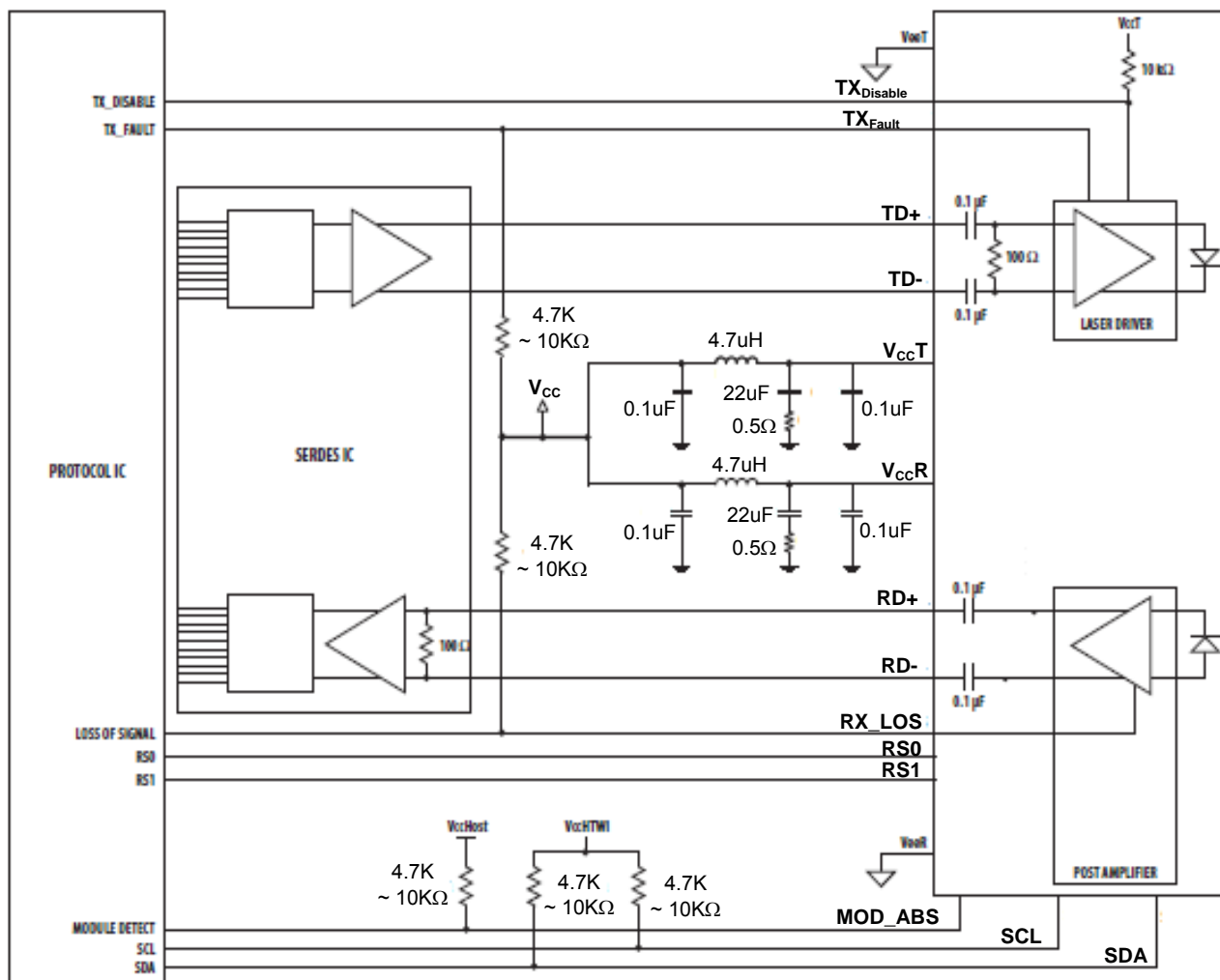

Fig. 6 SFP+ Host board Schematic Application

IDS-100808B-CSRR

Digital Diagnostic Functions

The IDS-100808B-CSRR SFP+ transceivers support the 2-wire serial communication protocol (I²C) as defined in the SFP+ MSA. Through this serial communication, these transceivers provide access to identification information that describes their capabilities, standard interfaces, manufacturer, and other information. In addition, these SFP+ transceivers provide enhanced digital diagnostic monitoring interface, which allows real-time access to device operating conditions such as internal temperature, laser bias current, transmitted optical power, received optical power and supply voltage. It also defines a sophisticated system of alarm and warning flags.

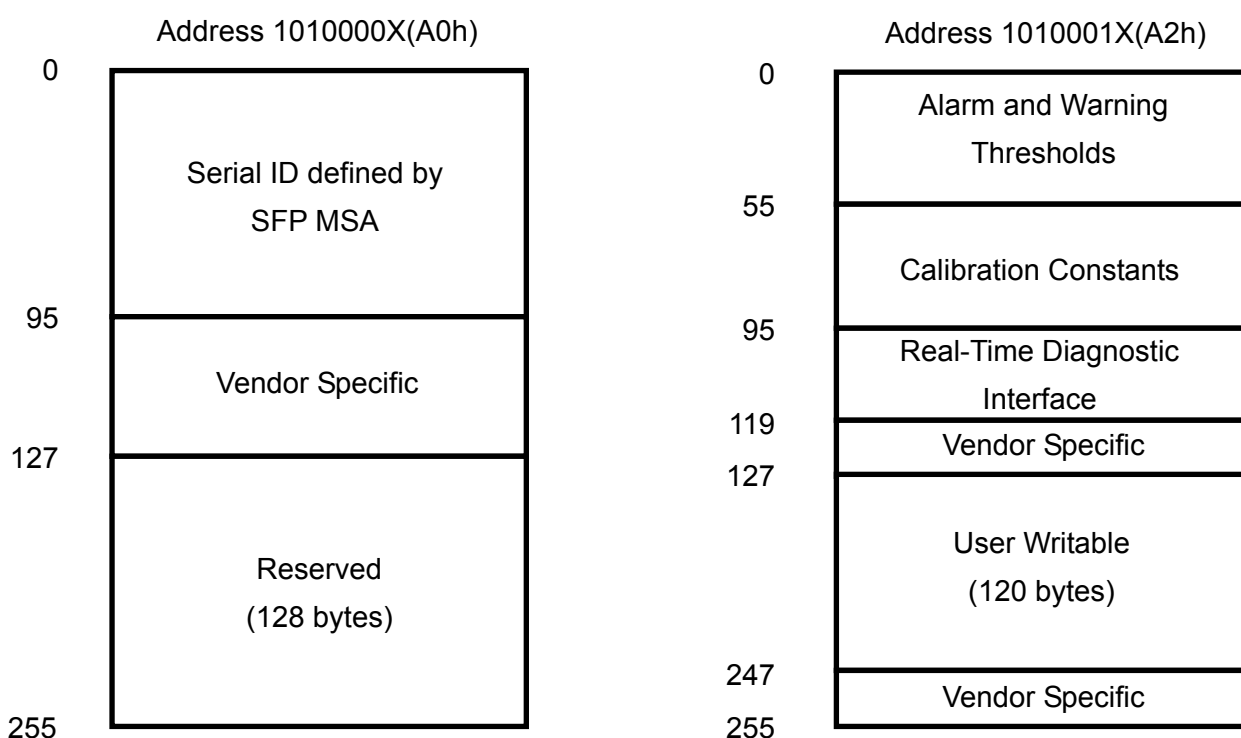

Fig. 7 Two-wire serial digital memory map

IDS-100808B-CSRR

Ordering Information

For more information on this or other products and their availability, please contact e-mail at sales@intecec.com.

①
②
-
③
④
⑤
⑥
-
⑦
⑧
⑨

No.	ITEM	Code	Description
①	Company	I	INTEC E&C
②	Form Factor	DS	Duplex SFP+
③	Data-rate	10	10Gbps
④	Tx wavelength	08	850nm
⑤	Rx wavelength	08	850nm
⑥	Optical interface	B	LC-UPC receptacle
⑦	Temperature range	C	0°C ~ 70°C
⑧	Transmission Distance	SR	300m
⑨	RoHS	R	RoHS compliant

Contact:

Add: A-14th, Gunpo IT Valley, 17, Gosan-ro 148beon-gil, Gunpo-si, Gyeonggi-do, Korea

TEL : +82-31-454-9315~7

FAX : +82-31-454-9388

E-mail:sales@intecec.com

<http://www.intecec.com>