

# IBS-C6xxyyC-H20R

---

## 6.144Gbps SC/APC Receptacle CWDM SFP+ Transceiver for CPRI (Common Public Radio Interface)

- **Single mode SFP+ Transceivers**
- **6.144Gb/s OBSAI/CPRI Transmission**
- **Compliant with MSA SFP+ specification**
- **Single +3.3V Power Supply**
- **Simplex SC/APC Connector**

### Features

- 18-Wavelength CWDM Transmitter from 1271nm to 1611nm, with step 20nm
- Standard Small Form Pluggable package with receptacle SC/APC connector
- Compliant with SFP MSA
- SFF-8472 compliant digital diagnostic monitoring function implemented
- Internally calibrated mode
- Uncooled CWDM DFB lasers Transmitter
- High sensitive PIN photodiode Receiver
- Single +3.3V power supply
- Operating case temperature; -30°C to +85°C
- Differential CML inputs and outputs
- Internally AC-Coupled electrical interface
- RoHS compliant

### Description

IBS-C6xxyyC-H20R SFP+ transceivers are designed to meet serial optical data communications specification. The transceivers are manufactured in hot pluggable capability package with pigtail SC/APC connector interface and made of metallized housing to obtain excellent EMI shielding.

The transmitter consists of DFB laser in an optical subassembly (OSA).

The OSA is driven by a custom IC which converts differential CML logic signals into a laser diode drive current. The receiver includes a planar InGaAs PIN-PD mounted with a transimpedance preamplifier IC in an OSA. The OSA is mated to a custom limiting-amplifier which provides post-amplification and signal detect function (Logic 0 indicates normal operation).

The transceivers are designed to used in a single power supply (+3.3V) and an operating temperature range of -30°C to +85°C.

### Applications

- Digital Wireless Repeaters
- Digital Wireless BTS Interconnects: OBSAI and CPRI Standards
- Metro Access Rings

# IBS-C6<sub>xxyy</sub>C-H20R

## Absolute Maximum Ratings

Parameter	Symbol	Min	Typ	Max	Unit
Storage Temperature	T <sub>ST</sub>	-40		+85	°C
Power Supply Voltage	V <sub>CC</sub>	0		3.6	V
Operating Humidity	H <sub>OP</sub>			85	% RH

## Recommended Operating Conditions

Parameter	Symbol	Min	Typ	Max	Unit
Operating Case Temperature	T <sub>c</sub>	-30		85	°C
Supply Voltage	V <sub>CC</sub>	3.1	3.3	3.5	V
Current	I <sub>CC</sub>			350	mA

## CWDM Wavelength

Parameter	Symbol	Min	Typ	Max	Unit
O-band Original	λ	1264.5	1271	1277.5	nm
	λ	1284.5	1291	1297.5	nm
	λ	1304.5	1311	1317.5	nm
	λ	1324.5	1331	1337.5	nm
	λ	1344.5	1351	1357.5	nm
E-band Extended	λ	1364.5	1371	1377.5	nm
	λ	1384.5	1391	1397.5	nm
	λ	1404.5	1411	1417.5	nm
	λ	1424.5	1431	1437.5	nm
	λ	1444.5	1451	1457.5	nm
S-band Short Wavelength	λ	1464.5	1471	1477.5	nm
	λ	1484.5	1491	1497.5	nm
	λ	1504.5	1511	1517.5	nm
	λ	1524.5	1531	1537.5	nm
C-band Conventional	λ	1544.5	1551	1557.5	nm
L-band Long Wavelength	λ	1564.5	1571	1577.5	nm
	λ	1584.5	1591	1597.5	nm
	λ	1604.5	1611	1617.5	nm

# IBS-C6xxyyC-H20R

## Transmitter Characteristics

Parameter	Symbol	Min	Typ	Max	Unit
Bit rate	B		6.144		Gbps
Wavelength	$\lambda_T$	$\lambda_C - 6.5$	$\lambda_C$	$\lambda_C + 6.5$	nm
Output Spectral Width (-20dB)	$\Delta\lambda$			1	nm
Average Launch Power	$P_o$	-2		+3	dBm
Extinction ratio	dB	4.5			dB
Side Mode Suppression Ratio	SMSR	30			dB
Differential data input swing	$V_{IN, p-p}$	200		1000	mV
TX_Disable Input High Voltage	$V_{IH}$	2.4			V
TX_Disable Input Low Voltage	$V_{IL}$			0.8	V
TX_Fault Output High Voltage	$V_{OH}$	Host Vcc - 0.5		Host Vcc	V
TX_Fault Output Low Voltage	$V_{OL}$	0		0.4	V
Relative intensity noise				-128	dB/Hz
Transmitter and Dispersion Penalty	TDP			2	dB
Average Launch Power of Off TX				-30	dBm

## Receiver Characteristics

Parameter	Symbol	Min	Typ	Max	Unit
Bit rate	B		6.144		Gbps
Wavelength	$\lambda_R$	$\lambda_C - 6.5$	$\lambda_C$	$\lambda_C + 6.5$	nm
Differential data output swing	$V_{OUT, p-p}$	200		800	mV
RX_LOS Output Voltage-high	$V_{OH}$	Host Vcc - 0.5		Host Vcc	V
RX_LOS Output Voltage-Low	$V_{OL}$	0		0.4	V
Rx Sensitivity (Note1)	$P_{min}$			-15	dBm
Maximum Input Power	$P_{max}$	0			dBm
LOS De-Assert	$LOS_D$			-16	dBm
LOS Assert	$LOS_A$	-30			dBm
LOS Hysteresis	$LOS_{HYS}$	0.5			dB

Note 1) Sensitivity and saturation level at PRBS2<sup>23</sup>-1, @6.144Gbps, BER 1x10<sup>-12</sup>

# IBS-C6<sub>xxyy</sub>C-H20R

## Block Diagram

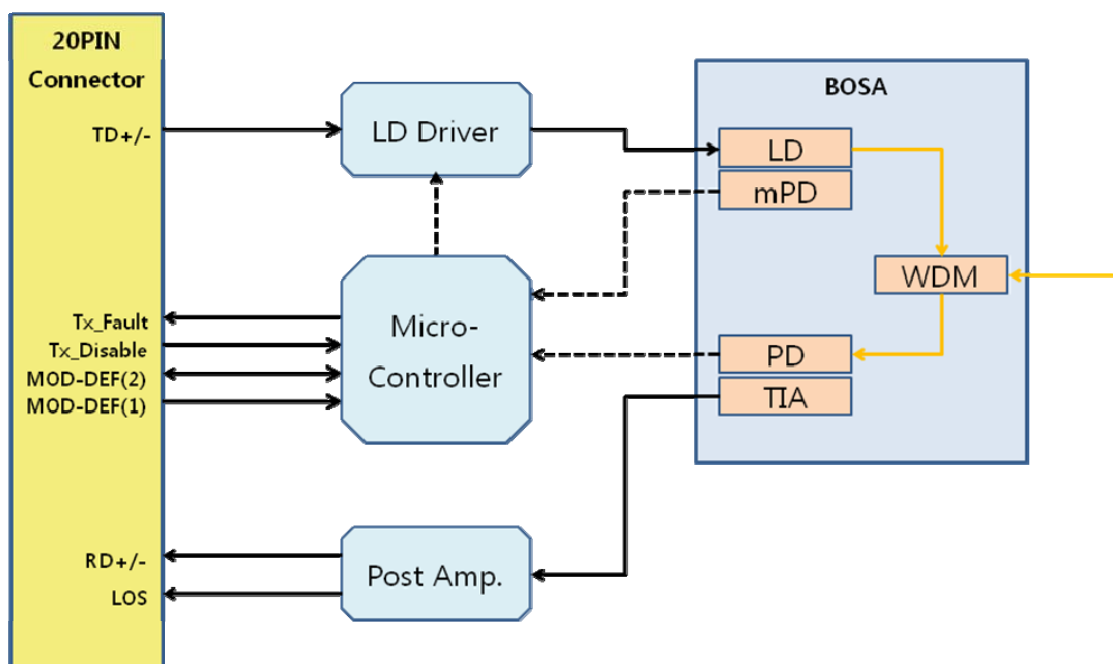

Fig. 1 Block Diagram

# IBS-C6<sub>xxyy</sub>C-H20R

## PIN description

These devices can be installed in or removed from any MSA-compliant Pluggable Small Form Factor port regardless of whether the host equipment is operating or not. These devices are simply inserted, electrical-interface first, under finger-pressure. Controlled hot-plugging is ensured by 3-stage pin sequencing at the electrical interface. See the Fig 2. As these devices are inserted, first contact is made by the housing ground shield, discharging any potentially component-damaging static electricity. Ground pins engage next and are followed by TX and RX power supplies. Finally, signal pins are connected.

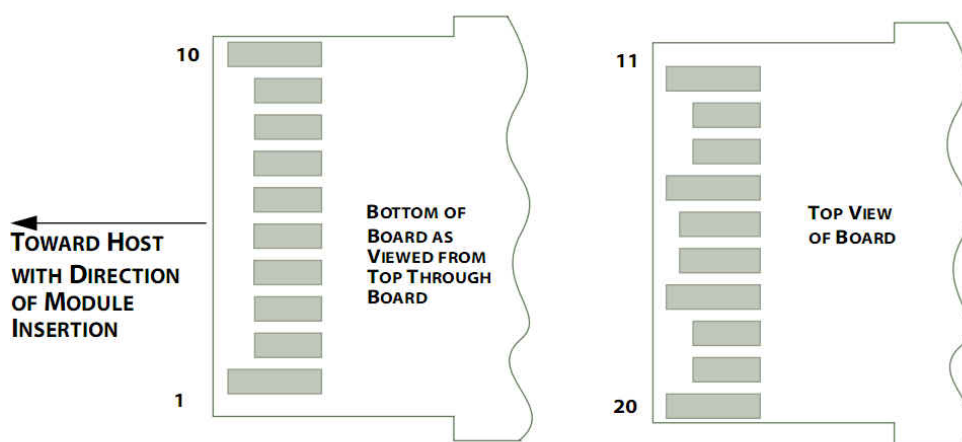

Fig. 2 SFP+ Transceiver Electrical Pad Layout

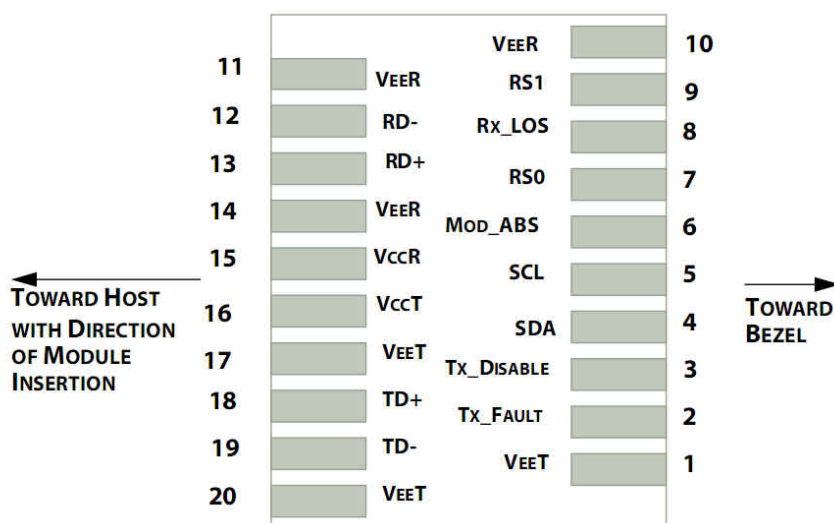

Fig. 3 Host PCB SFP+ Pinout

# IBS-C6xxyyC-H20R

## PIN assignment

Pin	Name	In/Out	Logic	Description	Note
1	VeeT			Module Transmitter Ground	
2	TX_Fault		LVTTTL	Module Transmitter Fault	2
3	TX_Dis	I	LVTTTL	Transmitter Disable; Turns off transmitter laser output	3
4	SDA	I/O	LVTTTL	2-Wire Serial Interface Data Line	
5	SCL	I/O	LVTTTL	2-Wire Serial Interface Clock	
6	Mod_ABS			Module Absent, connected to VeeT or VeeR in the module	2
7	Rate Sel			N.C.	
8	RX_LOS	O	LVTTTL	Receiver Loss Of Signal Indication (In FC designated as RX_LOS and in Ethernet designated as Signal Detect)	2
9	VeeR			Module Receiver Ground	
10	VeeR			Module Receiver Ground	1
11	VeeR			Module Receiver Ground	1
12	RD-	O	CML	Receiver Inverted Data Output	
13	RD+	O	CML	Receiver Non-Inverted Data Output	
14	VeeR			Module Receiver Ground	1
15	VccR			Module Receiver 3.3 V Supply	
16	VccT			Module Transmitter 3.3 V Supply	
17	VeeT			Module Transmitter Ground	1
18	TD+	I	CML	Transmitter Non-Inverted Data Input	
19	TD-	I	CML	Transmitter Inverted Data Input	
20	VeeT			Module Transmitter Ground	1

### Note

- 1: Module ground pins are isolated from the module case and chassis ground within the module.
- 2: Shall be pulled up with 4.7k to 10k ohm to a voltage between 3.15V and 3.45V on the host board.
- 3: Shall be pulled up with 4.7k to 10k ohm to VccT in the module.



# IBS-C6xxyyC-H20R

## Host Board Power Supply filtering

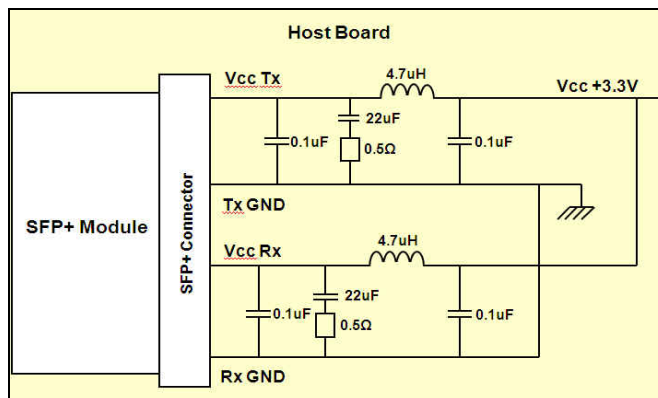

Fig. 6 Host board power supply filtering

## Recommended Circuit Schematic

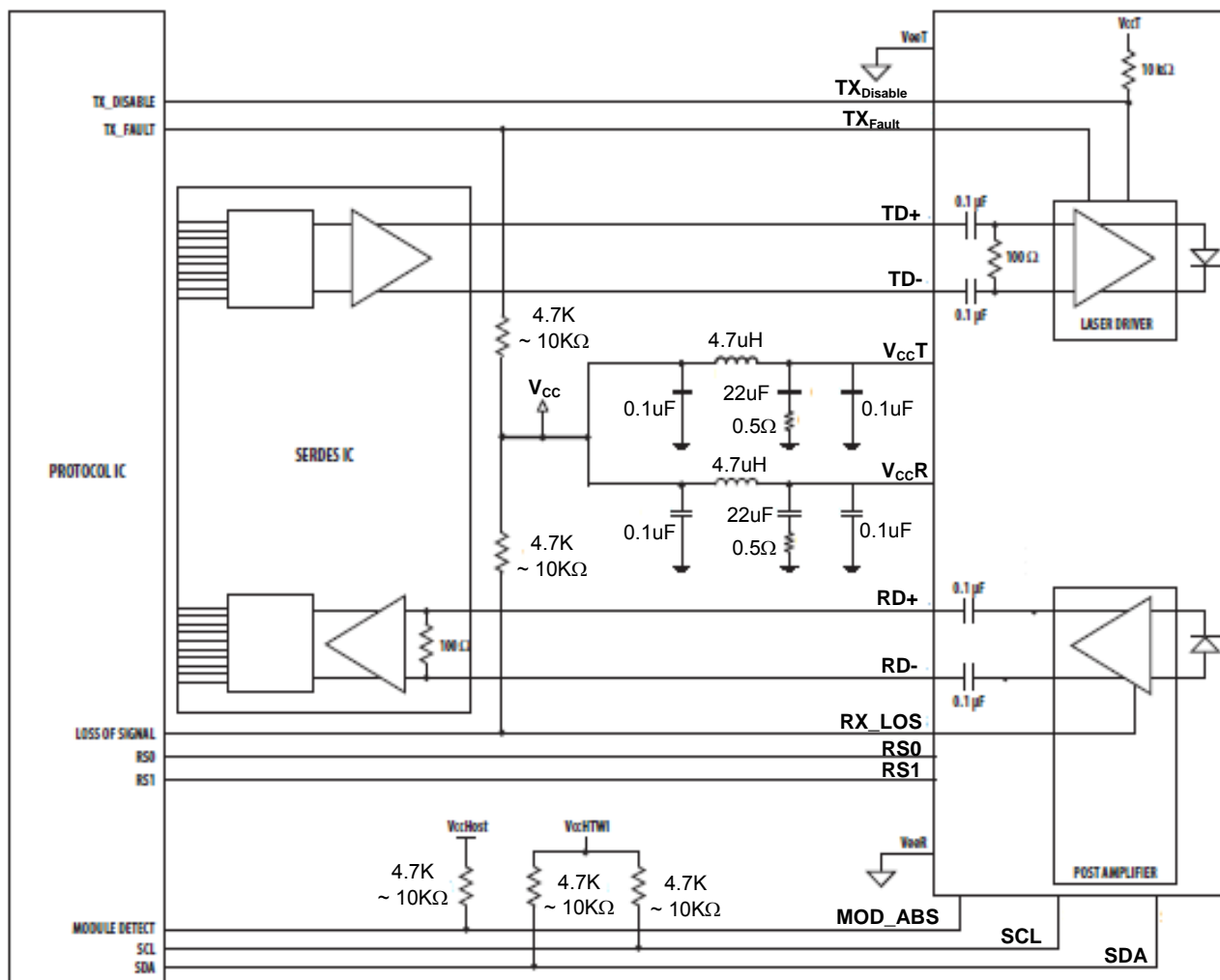

Fig. 7 SFP+ Host board Schematic Application



# IBS-C6xxyyC-H20R

## Digital Diagnostic Functions

The IBS-C6xxyyC-H20R SFP+ transceivers support the 2-wire serial communication protocol (I<sup>2</sup>C) as defined in the SFP MSA. Through this serial communication, these transceivers provide access to identification information that describes their capabilities, standard interfaces, manufacturer, and other information. In addition, these SFP transceivers provide enhanced digital diagnostic monitoring interface, which allows real-time access to device operating conditions such as internal temperature, laser bias current, transmitted optical power, received optical power and supply voltage. It also defines a sophisticated system of alarm and warning flags.

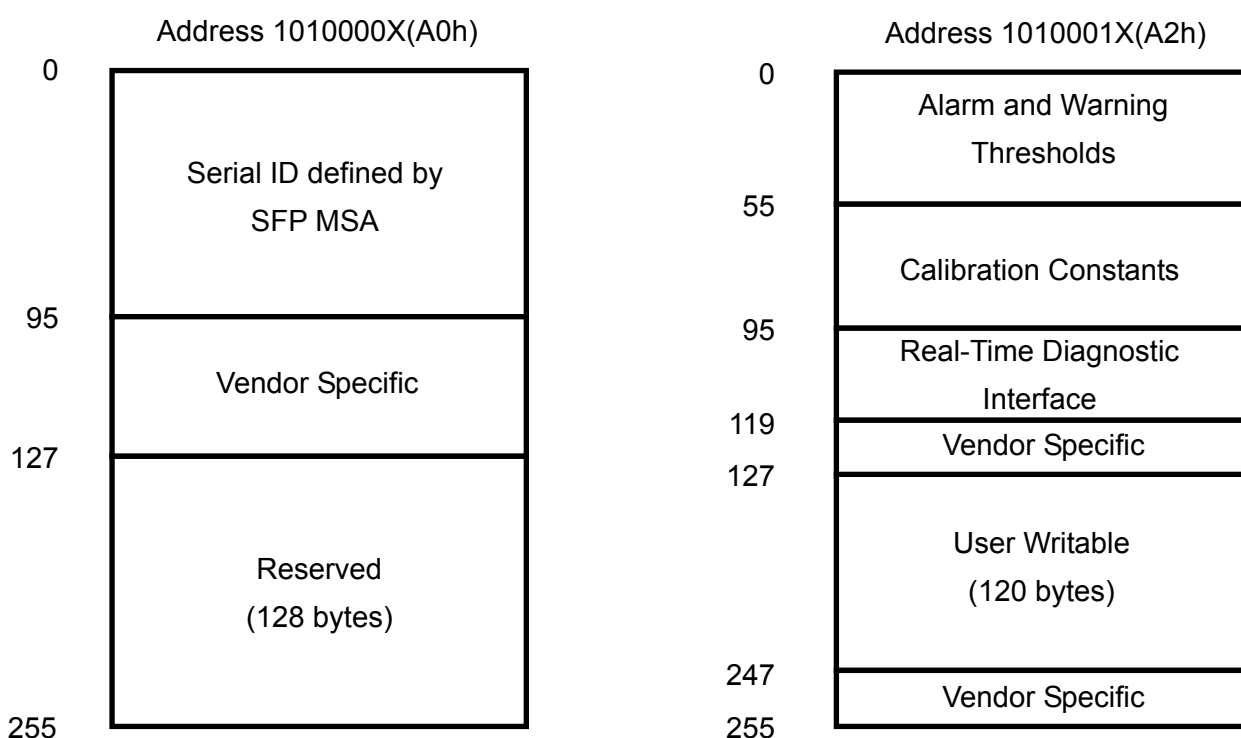

Fig. 8 Two-wire serial digital memory map

# IBS-C6xxyyC-H20R

## Ordering Information

For more information on this or other products and their availability, please contact e-mail at [sales@intecec.com](mailto:sales@intecec.com).

①	②	-	③	④	⑤	⑥	-	⑦	⑧	⑨
---	---	---	---	---	---	---	---	---	---	---

No.	ITEM	Code	Description
①	Company	I	INTEC E&C
②	Form Factor	BS	BIDI SFP+
③	Data-rate	C6	6.144Gbps
④	Tx wavelength	xx	27(1270nm), 61(1610nm)
⑤	Rx wavelength	yy	27(1270nm), 61(1610nm)
⑥	Optical interface	C	SC-APC receptacle
⑦	Temperature range	H	-30°C ~ 85°C
⑧	Link budget	20	20km
⑨	RoHS	R	RoHS compliant

## Contact:

Add: A-14th, Gunpo IT Valley, 17, Gosan-ro 148beon-gil, Gunpo-si, Gyeonggi-do, Korea

TEL : +82-31-454-9315~7

FAX : +82-31-454-9388

E-mail: [sales@intecec.com](mailto:sales@intecec.com)

<http://www.intecec.com>